



PHOENIX

SPECIFICATIONS

VIVID

FILTERED SINK MIXER 220MM GOOSENECK WITH FILTERS

PRODUCT CODE: V737 CHR
 FINISH: CHROME
 WELS: 5 STAR - 6 LT/MIN

INFORMATION:

MATERIAL: BRASS
 TEMPERATURE RATING: MIN 1° - MAX 75°
 PRESSURE RATING: MIN 150 kPa - MAX 500 kPa



AVAILABLE IN:



CHROME

FOR MORE INFORMATION VISIT
www.phoenixtapware.com.au

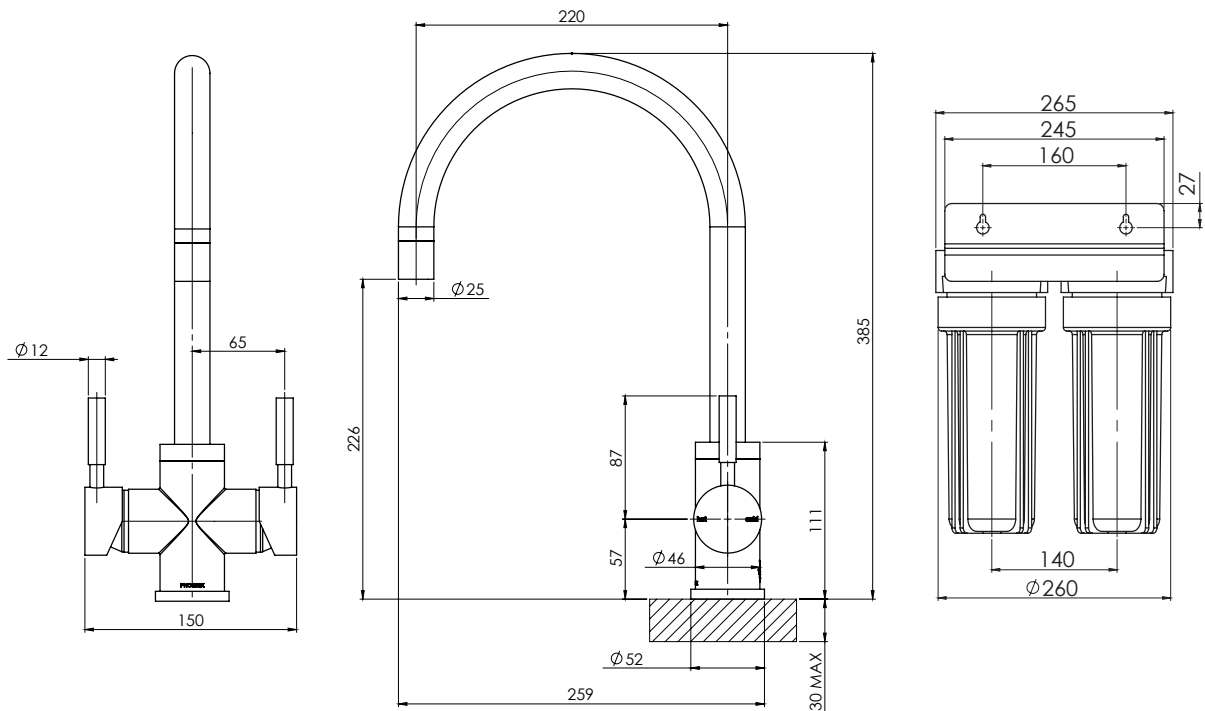

PLEASE [CLICK HERE TO VIEW FULL WARRANTY](#)

While we aim to ensure the specifications shown are correct at time of printing, Phoenix Tapware reserves the right to make modifications without prior notice. Always use the physical product measurements for mark-ups and roughing-in as the line drawing shown may differ from the actual product over time. All measurements are shown in millimetres.

www.phoenixtapware.com.au
03 9780 4200



PHOENIX

SPECIFICATIONS

VIVID

FILTERED SINK MIXER 220MM GOOSENECK WITH FILTERS

PRODUCT CODE:

V737 CHR

FINISH:

CHROME

WELS:

5 STAR - 6 LT/MIN



PARTS LIST

1. MIXER BODY
2. DRESS PLATE
3. MIXER HANDLE
4. MIXER DOME
5. FILTERED WATER MIXER HANDLE
6. 35MM CARTRIDGE
7. MIXER LOCKNUT M37X1.5MM
8. 25MM CARTRIDGE
9. LOCKING NUT 25MM CARTRIDGE
10. MOUNTING PLATE
11. M6 THREADED ROD
12. M6 NUT
13. FLEXIBLE HOSE 450MM COLD
14. FLEXIBLE HOSE 450MM HOT
15. FILTER FLEXIBLE HOSE 450MM
16. FILTER MOUNTING PLATE
17. SPOUT 220MM GOOSENECK
18. PIN LEVER
19. GRUB SCREW M5X4MM
20. AERATOR RETAINER
21. AERATOR
22. O-RING 6X1.5MM
23. O-RING 21X2.5MM
24. O-RING 7X2.0MM
25. O-RING 43X3MM
26. WASHER
27. O-RING 6.6X1.0MM
28. SPOUT BOSS
29. SPOUT DISC
30. PULL OUT TOP FLANGE
31. O-RING 25X2MM
32. O-RING 26X3.0MM

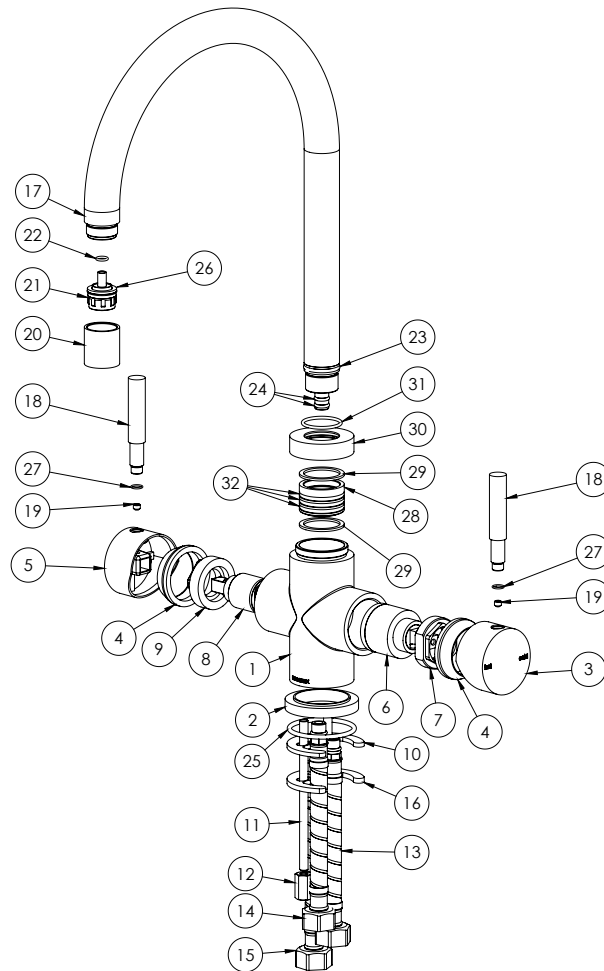

MAINTENANCE AND CARE:

- All surfaces should be cleaned with mild liquid detergent or soap and water.
- Do not use cream cleaners or citrus based cleaning products, as they are abrasive.
- Use of unsuitable cleaning agents may damage the surface. Any damage caused in this way will not be covered by warranty.

PACKAGING INCLUDES

- 1 x Filtered sink mixer 220mm gooseneck
- 1 x Installation kit
- 1 x 450mm braided flexible cold hose
- 1 x 450mm braided flexible hot hose
- 1 x 450mm braided flexible filter hose
- 1 x Adaptor
- 1 x Dress plate
- 2 x Filters
- 1 x Installation instructions
- 1 x Warranty card

PLEASE [CLICK HERE](#) TO VIEW FULL WARRANTY

While we aim to ensure the specifications shown are correct at time of printing, Phoenix Tapware reserves the right to make modifications without prior notice. Always use the physical product measurements for mark-ups and roughing-in as the line drawing shown may differ from the actual product over time. All measurements are shown in millimetres.

www.phoenixtapware.com.au
03 9780 4200