



PHOENIX

VEZZ

FLEXIBLE HOSE SINK MIXER SQUARE

PRODUCT CODE: I0373100BN
 FINISH: BRUSHED NICKEL
 WELS: 5 STAR - 6.0 LT/MIN

INFORMATION:

MATERIAL: BRASS
 TEMPERATURE RATING: MIN 1° - MAX 75°
 PRESSURE RATING: MIN 150 kPa - MAX 500 kPa

CONSUMER UNIT:

SIZE: L 610MM x W 290MM x H 75MM
 GROSS WEIGHT: 3 KG
 BARCODE EAN-13: 9 320594 003 937

SPECIFICATIONS



AVAILABLE IN:

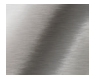

CHROME

BRUSHED NICKEL

FOR MORE INFORMATION VISIT www.phoenixtapware.com.au

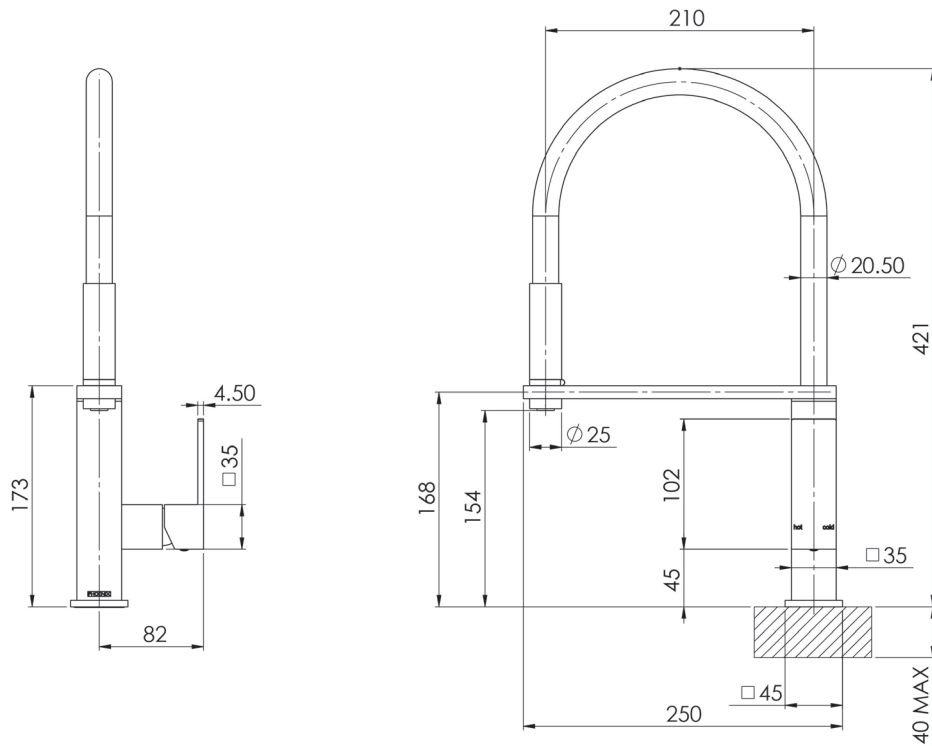

PLEASE [CLICK HERE TO VIEW FULL WARRANTY](#)

While we aim to ensure the specifications shown are correct at time of printing, Phoenix Tapware reserves the right to make modifications without prior notice. Always use the physical product measurements for mark-ups and roughing-in as the line drawing shown may differ from the actual product over time. All measurements are shown in millimetres.

Vezz is a Registered Trademark of Phoenix Industries Pty. Ltd.

V050716

www.phoenixtapware.com.au
03 9780 4200



PHOENIX

SPECIFICATIONS

VEZZ

FLEXIBLE HOSE SINK MIXER SQUARE

PRODUCT CODE:

I0373100BN

FINISH:

BRUSHED NICKEL

WELS:

5 STAR - 6.0 LT/MIN



PARTS LIST

1. SIDE LEVER BODY
2. CARTRIDGE SEAT
3. 25MM CARTRIDGE
4. MIXER LOCKNUT
5. MIXER DOME
6. MIXER HANDLE
7. MIXER SHAFT
8. PLASTIC SPACER
9. MIXER HOSE CRADLE
10. SPOUT BLOCK
11. DRESS PLATE
12. HAND PIECE BODY
13. HAND PIECE NOZZLE
14. HAND PIECE RING
15. HAND PIECE FLEXIBLE HOSE
16. HAND PIECE RUBBER TUBE
17. AERATOR
18. SCREW M4X12MM
19. GRUB SCREW M5X5MM
20. SCREW CAP
21. O-RING 36X3.0MM
22. PLASTIC LOCKNUT
23. LOCKNUT GASKET
24. THREADED TAIL
25. SWIVEL SPACER
26. FLEXIBLE HOSE 450MM COLD
27. FLEXIBLE HOSE 450MM HOT
28. MOUNTING DISC

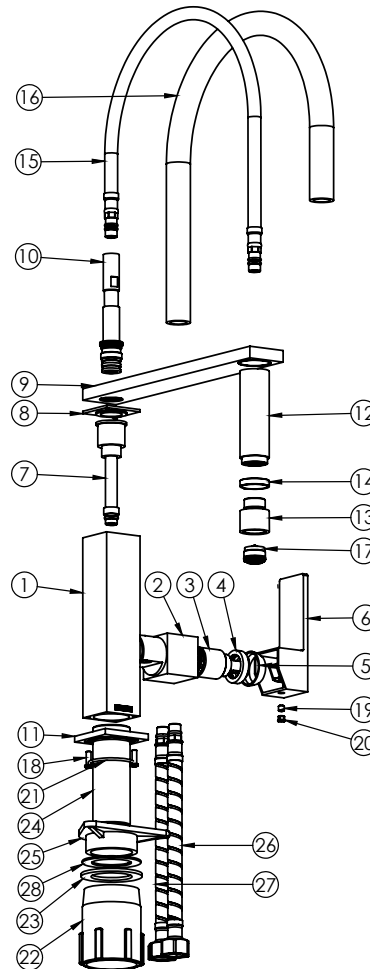

MAINTENANCE AND CARE:

- Chrome plated surfaces should be cleaned with mild liquid detergent or soap and water:
- Do not use cream cleaners or citrus based cleaning products, as they are abrasive.
- Use of unsuitable cleaning agents may damage the surface. Any damage caused in this way will not be covered by warranty.

PACKAGING INCLUDES

- 1 x Flexible Hose Sink Mixer
- 1 x 450mm braided flexible cold hose
- 1 x 450mm braided flexible hot hose
- 1 x Installation kit
- 1 x Installation instructions
- 1 x Warranty card

PLEASE [CLICK HERE](#) TO VIEW FULL WARRANTY

While we aim to ensure the specifications shown are correct at time of printing, Phoenix Tapware reserves the right to make modifications without prior notice. Always use the physical product measurements for mark-ups and roughing-in as the line drawing shown may differ from the actual product over time. All measurements are shown in millimetres.

Vezz is a Registered Trademark of Phoenix Industries Pty. Ltd.

V050716

www.phoenixtapware.com.au
03 9780 4200