



PHOENIX

SPECIFICATIONS

ALIA

WALL TOP ASSEMBLIES 15MM EXTENDED SPINDLES

PRODUCT CODE:	110-0670-00
FINISH:	CHROME
WELS:	N/A

INFORMATION:

TEMPERATURE RATING:	MIN 1° - MAX 75°
PRESSURE RATING:	MIN 150 kPa - MAX 500 kPa



ALSO AVAILABLE IN:



BRUSHED
GOLD



BRUSHED
NICKEL

FOR MORE INFORMATION VISIT
www.phoenixtapware.com.au

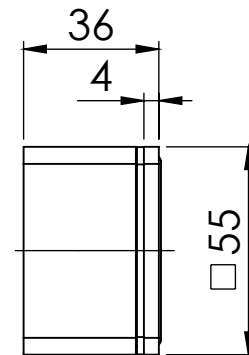
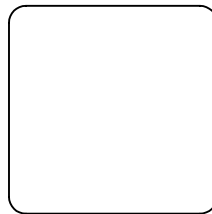
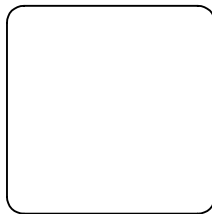

PLEASE [CLICK HERE TO VIEW FULL WARRANTY](#)

While we aim to ensure the specifications shown are correct at time of printing, Phoenix Tapware reserves the right to make modifications without prior notice. Always use the physical product measurements for mark-ups and roughing-in as the line drawing shown may differ from the actual product over time. All measurements are shown in millimetres.

www.phoenixtapware.com.au
03 9780 4200



ALIA

WALL TOP ASSEMBLIES 15MM EXTENDED SPINDLES

PRODUCT CODE:

110-0670-00

FINISH:

CHROME

WELS:

N/A



PARTS LIST

1. 71MM CARTRIDGE
2. FIBER WASHER
3. LOCKNUT
4. SPINDLE ADAPTOR
5. BACKPLATE
6. DRESS PLATE
7. TAP HANDLE HOT
8. TAP LOCKNUT
9. GRUB SCREW M5X5
10. GRUB SCREW CAP
11. O-RING 45X2.5MM
12. TAP HANDLE COLD

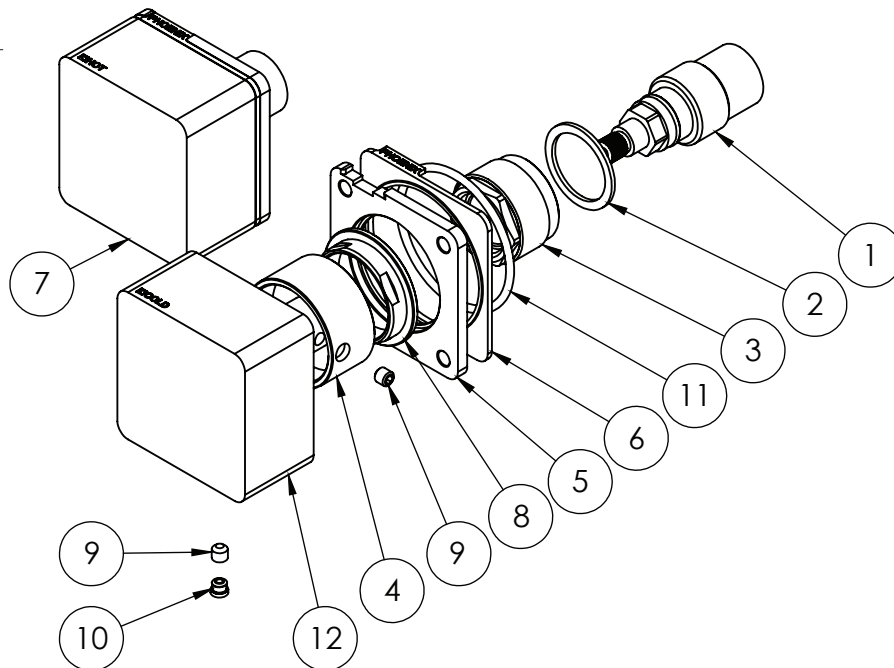

MAINTENANCE AND CARE:

- All surfaces should be cleaned with mild liquid detergent or soap and water.
- Do not use cream cleaners or citrus based cleaning products, as they are abrasive.
- Use of unsuitable cleaning agents may damage the surface. Any damage caused in this way will not be covered by warranty.

PACKAGING INCLUDES

- 1 x Wall top assemblies
- 2 x Tap handle
- 1 x Dress plate hot
- 1 x Dress plate cold
- 2 x Tap locknut
- 2 x Spline adaptors
- 1 x Installation kit
- 1 x Installation instructions
- 1 x Warranty card

PLEASE [CLICK HERE](#) TO VIEW FULL WARRANTY

While we aim to ensure the specifications shown are correct at time of printing, Phoenix Tapware reserves the right to make modifications without prior notice. Always use the physical product measurements for mark-ups and roughing-in as the line drawing shown may differ from the actual product over time. All measurements are shown in millimetres.

www.phoenixtapware.com.au
03 9780 4200