



PHOENIX

SPECIFICATIONS

ORTHO

TWIN SHOWER / WALL MIXER

PRODUCT CODE: 100-7920-00
 FINISH: CHROME
 WELS: N/A

INFORMATION:

TEMPERATURE RATING: MIN 1° - MAX 75°
 PRESSURE RATING: MIN 150 kPa - MAX 500 kPa

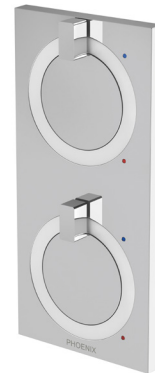

AVAILABLE IN:



CHROME MATTE BRUSHED NICKEL

FOR MORE INFORMATION VISIT www.phoenixtapware.com.au

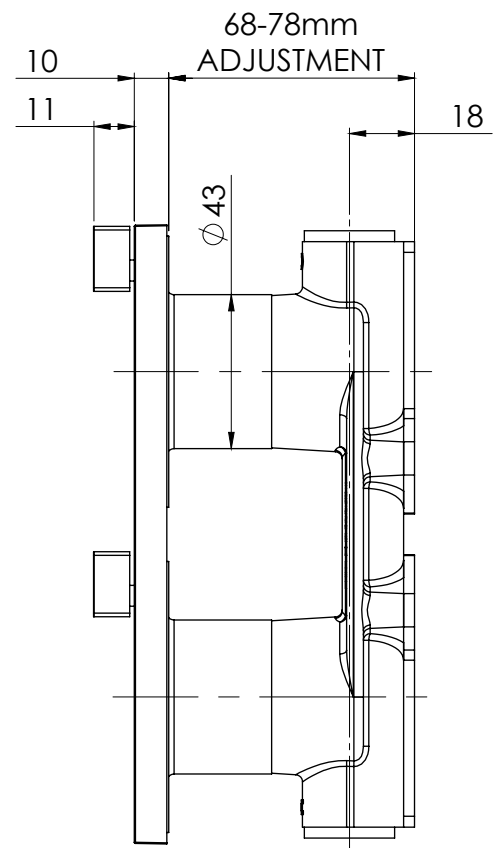
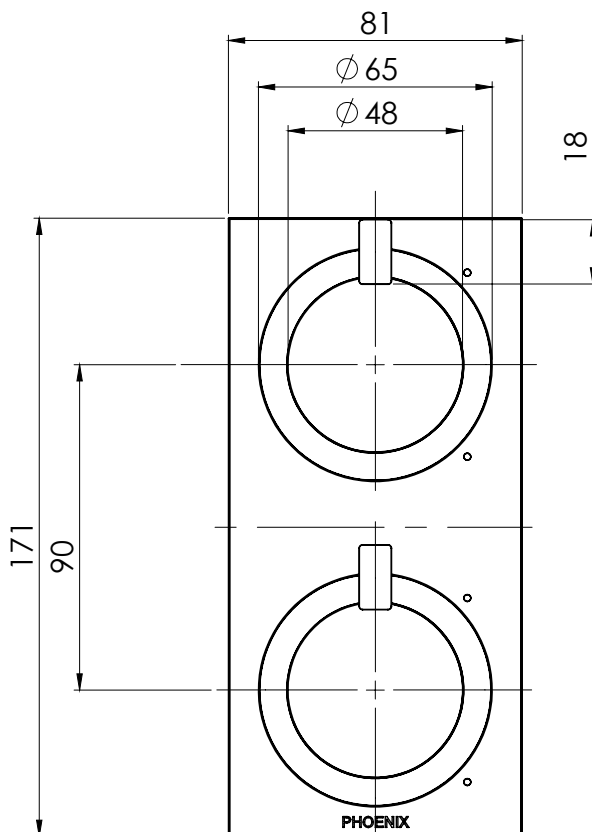

PLEASE [CLICK HERE TO VIEW FULL WARRANTY](#)

While we aim to ensure the specifications shown are correct at time of printing, Phoenix Tapware reserves the right to make modifications without prior notice. Always use the physical product measurements for mark-ups and roughing-in as the line drawing shown may differ from the actual product over time. All measurements are shown in millimetres.

A Registered Design and Trademark of Phoenix Industries Pty. Ltd

V260618

www.phoenixtapware.com.au
03 9780 4200



PHOENIX

SPECIFICATIONS

ORTHO

TWIN SHOWER / WALL MIXER

PRODUCT CODE:

100-7920-00

FINISH:

CHROME

WELS:

N/A

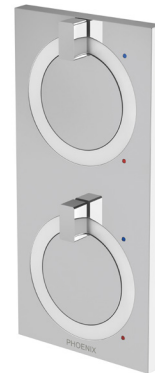

PARTS LIST

1. LEVER HANDLE
2. 33MM PROGRESSIVE CARTRIDGE
3. TWIN MIXER BREACH
4. ADJUSTMENT FLANGE
5. OUTER RING
6. SCREW M3X6
7. SCREW M4X10
8. DRESS PLATE
9. LOCKNUT
10. FLANGE GASKET
11. O-RING 75X2.0
12. MIXER MOUNTING DISK
13. INNER RING
14. SPLINED CAP
15. COLOUR INDICATOR BLUE
16. COLOUR INDICATOR RED
17. GRUB SCREW M3X4
18. SCREW M3.5X30
19. ADJUSTMENT PAD

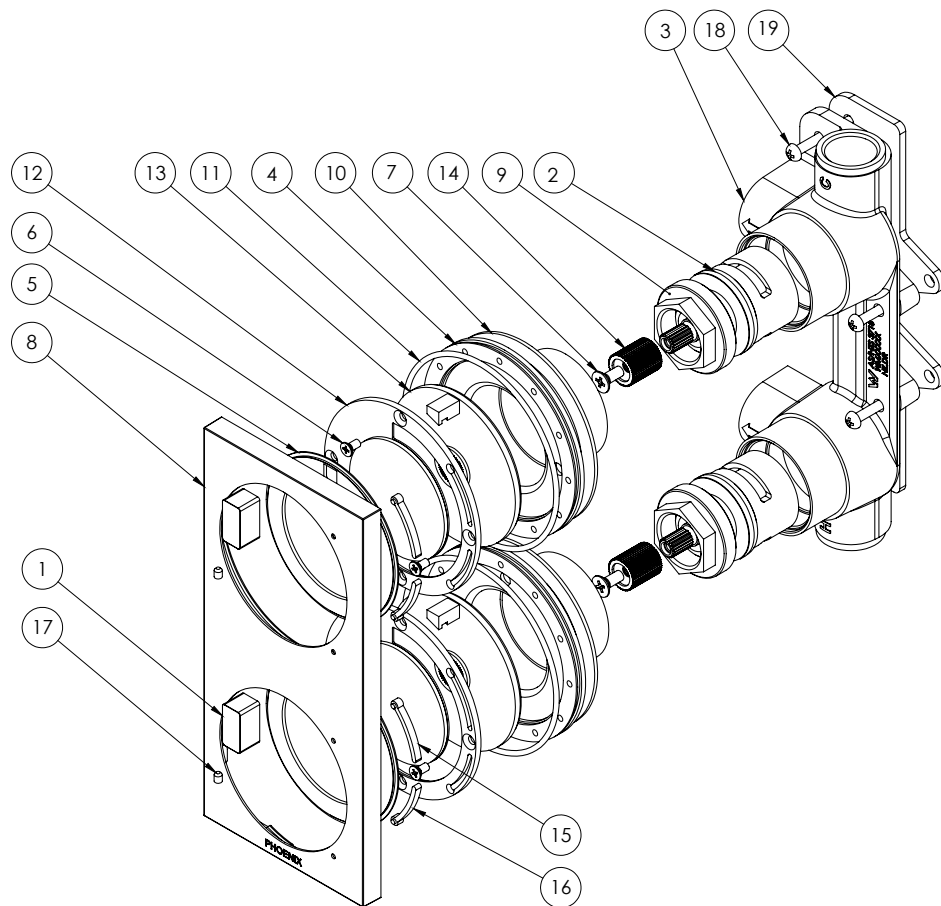

MAINTENANCE AND CARE:

- All surfaces should be cleaned with mild liquid detergent or soap and water.
- Do not use cream cleaners or citrus based cleaning products, as they are abrasive.
- Use of unsuitable cleaning agents may damage the surface. Any damage caused in this way will not be covered by warranty.

PACKAGING INCLUDES

- 1 x Twin wall mixer
- 1 x Dress plate
- 2 x Extra colour rings
- 2 x Handles
- 1 x Installation kit
- 1 x Installation instructions
- 1 x Warranty card

PLEASE [CLICK HERE](#) TO VIEW FULL WARRANTY

While we aim to ensure the specifications shown are correct at time of printing, Phoenix Tapware reserves the right to make modifications without prior notice. Always use the physical product measurements for mark-ups and roughing-in as the line drawing shown may differ from the actual product over time. All measurements are shown in millimetres.

A Registered Design and Trademark of Phoenix Industries Pty. Ltd

V260618

www.phoenixtapware.com.au
03 9780 4200