



PHOENIX

SPECIFICATIONS

TOI

WALL BASIN / BATH MIXER SET 180MM

PRODUCT CODE: 108-7810-60
 FINISH: CHROME / MATTE BLACK
 WELS: 5 STAR - 6.0 LT/MIN

INFORMATION:

TEMPERATURE RATING: MIN 1° - MAX 75°
 PRESSURE RATING: MIN 150 kPa - MAX 500 kPa



ALSO AVAILABLE IN:

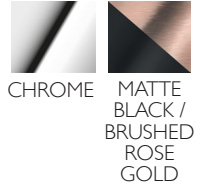

FOR MORE INFORMATION VISIT www.phoenixtapware.com.au

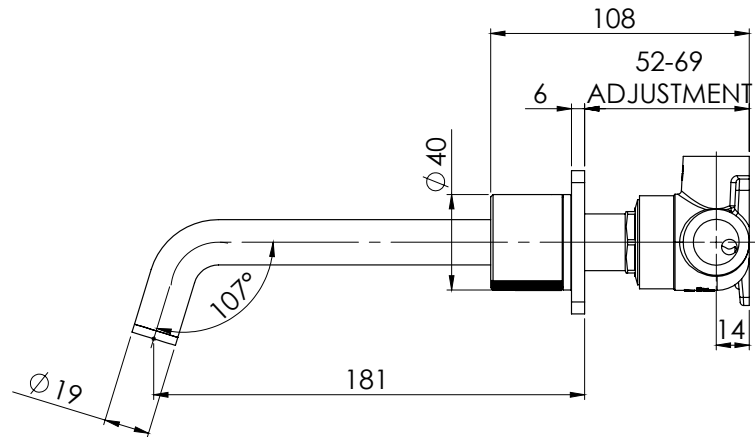
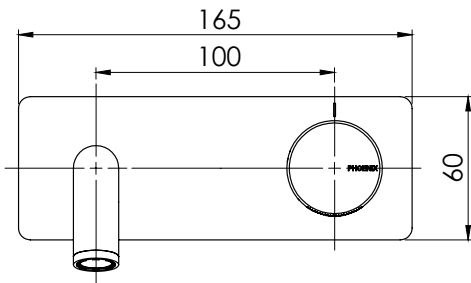

PLEASE [CLICK HERE](#) TO VIEW FULL WARRANTY

While we aim to ensure the specifications shown are correct at time of printing, Phoenix Tapware reserves the right to make modifications without prior notice. Always use the physical product measurements for mark-ups and roughing-in as the line drawing shown may differ from the actual product over time. All measurements are shown in millimetres.

Designed and Registered in Australia by Phoenix Industries Pty. Ltd
V231116

www.phoenixtapware.com.au
03 9780 4200



PHOENIX

SPECIFICATIONS

TOI

WALL BASIN / BATH MIXER SET 180MM

PRODUCT CODE: 108-7810-60
 FINISH: CHROME / MATTE BLACK
 WELS: 5 STAR - 6.0 LT/MIN

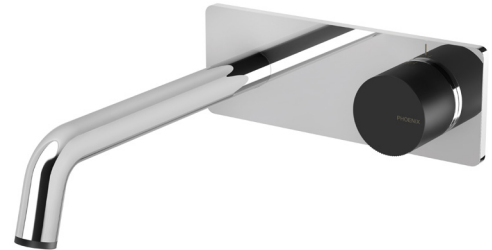

PARTS LIST

1. WALL BREACH 180MM
2. 33MM PROGRESSIVE CARTRIDGE
3. CARTRIDGE LOCKNUT
4. O-RING 32X2.0MM
5. SPINDLE EXTENSION
6. COUNTERSUNK SCREW
7. WALL BACK PLATE
8. LOCKNUT
9. SPOUT ADAPTER
10. O-RING 11X2.0MM
11. HANDLE
12. HANDLE WASHER
13. GRUB SCREW M5X5
14. SPOUT
15. AERATOR RETAINER
16. O-RING 14X1.0MM
17. AERATOR
18. GRUB SCREW M5X4
19. GRUB SCREW CAP
20. M14 TEST CAP

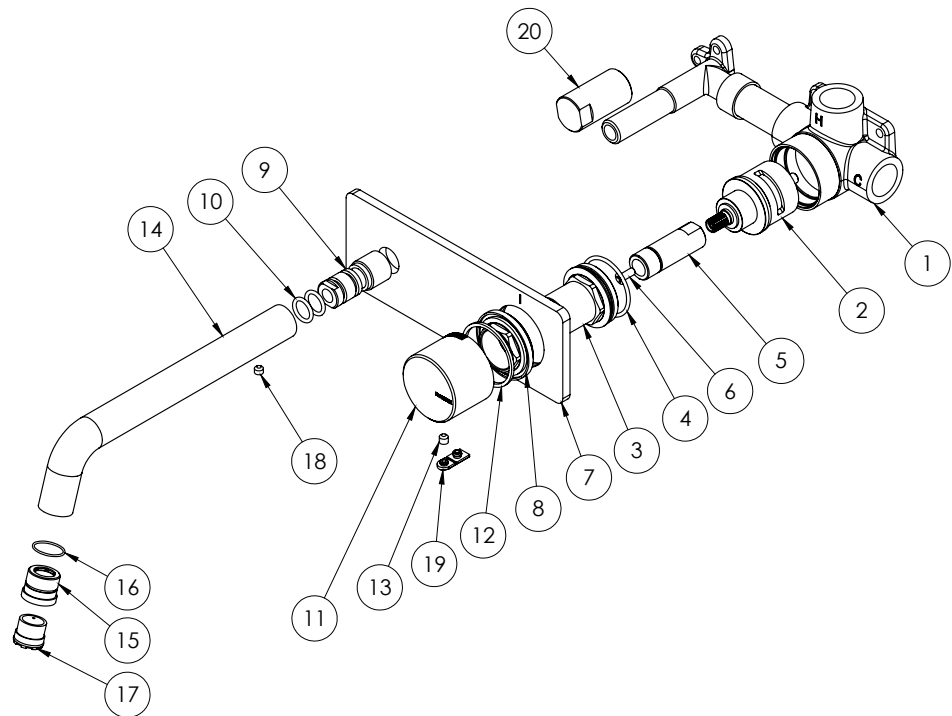

MAINTENANCE AND CARE:

- All surfaces should be cleaned with mild liquid detergent or soap and water.
- Do not use cream cleaners or citrus based cleaning products, as they are abrasive.
- Use of unsuitable cleaning agents may damage the surface. Any damage caused in this way will not be covered by warranty.

PACKAGING INCLUDES

- 1 x Wall mixer body
- 1 x Spout
- 1 x Locknut & plastic washer
- 1 x Free flow aerator & aerator key
- 1 x M14 adaptor, o-rings & M5 grub screw
- 1 x Handle
- 1 x Wall backplate
- 1 x Installation kit
- 1 x Installation instructions
- 1 x Warranty card

PLEASE [CLICK HERE](#) TO VIEW FULL WARRANTY

While we aim to ensure the specifications shown are correct at time of printing, Phoenix Tapware reserves the right to make modifications without prior notice. Always use the physical product measurements for mark-ups and roughing-in as the line drawing shown may differ from the actual product over time. All measurements are shown in millimetres.

Designed and Registered in Australia by Phoenix Industries Pty. Ltd
 V231116

www.phoenixtapware.com.au
 03 9780 4200