



# PHOENIX

## SPECIFICATIONS

### VIVID SLIMLINE UP

### WALL BASIN / BATH MIXER SET

PRODUCT CODE: 112-7813-30  
 FINISH: GUN METAL  
 WELS: 6 STAR - 4.0 LT/MIN

#### INFORMATION:

TEMPERATURE RATING: MIN 1° - MAX 75°  
 PRESSURE RATING: MIN 150 kPa - MAX 500 kPa

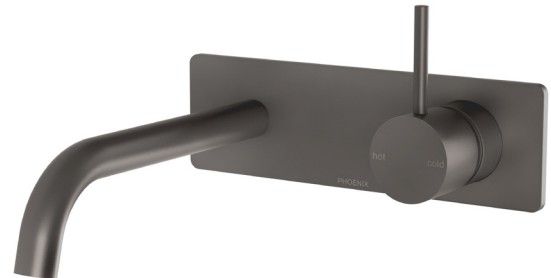

AVAILABLE IN:



FOR MORE INFORMATION VISIT  
[www.phoenixtapware.com.au](http://www.phoenixtapware.com.au)

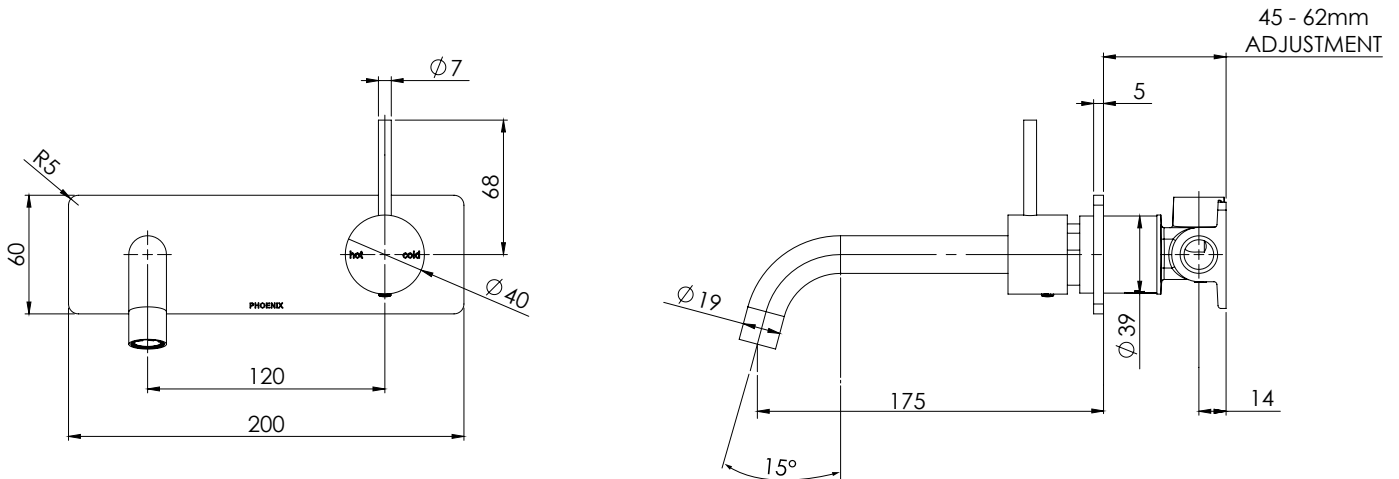

PLEASE [CLICK HERE TO VIEW FULL WARRANTY](#)

While we aim to ensure the specifications shown are correct at time of printing, Phoenix Tapware reserves the right to make modifications without prior notice. Always use the physical product measurements for mark-ups and roughing-in as the line drawing shown may differ from the actual product over time. All measurements are shown in millimetres.

[www.phoenixtapware.com.au](http://www.phoenixtapware.com.au)  
 03 9780 4200



### VIVID SLIMLINE UP

### WALL BASIN / BATH MIXER SET

PRODUCT CODE:

112-7813-30

FINISH:

GUN METAL

WELS:

6 STAR - 4.0 LT/MIN



#### PARTS LIST

1. WALL BREACH
2. WALL MIXER SLEEVE
3. LOCKNUT DOME
4. DRESS PLATE
5. O-RING 39X2.5MM
6. AERATOR
7. GRUB SCREW M5X4
8. SCREW CAP
9. SPOUT ADAPTER
10. O-RING 11X2.0MM
11. 35MM CARTRIDGE
12. CURVED WALL SPOUT
13. HANDLE
14. PIN LEVER
15. GRUB SCREW M5X4
16. O-RING 33X2.0 MM
17. SCREW
18. TEST CAP
19. FREE FLOW AERATOR

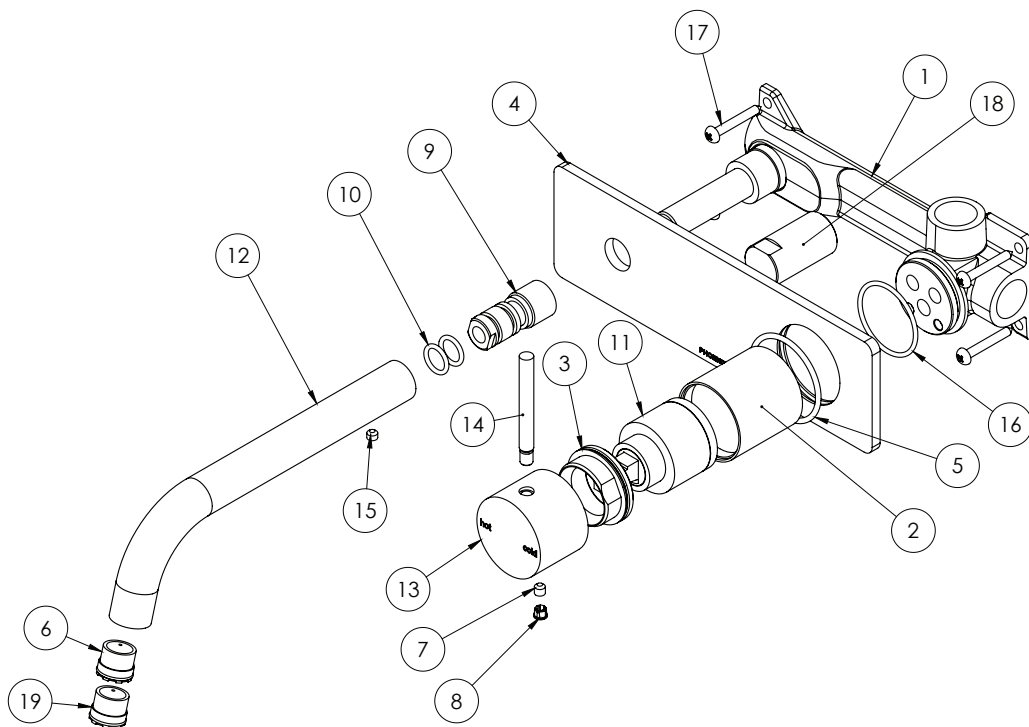

#### MAINTENANCE AND CARE:

- All surfaces should be cleaned with mild liquid detergent or soap and water.
- Do not use cream cleaners or citrus based cleaning products, as they are abrasive.
- Use of unsuitable cleaning agents may damage the surface. Any damage caused in this way will not be covered by warranty.

#### PACKAGING INCLUDES

- 1 x Wall basin / bath set
- 1 x Aerator key
- 1 x Dress plate
- 1 x Mixer handle
- 1 x Spout
- 1 x Installation kit
- 1 x Installation instructions
- 1 x Warranty card

PLEASE [CLICK HERE](#) TO VIEW FULL WARRANTY

While we aim to ensure the specifications shown are correct at time of printing, Phoenix Tapware reserves the right to make modifications without prior notice. Always use the physical product measurements for mark-ups and roughing-in as the line drawing shown may differ from the actual product over time. All measurements are shown in millimetres.

[www.phoenixtapware.com.au](http://www.phoenixtapware.com.au)  
03 9780 4200