



# PHOENIX

## SPECIFICATIONS

### NOSTALGIA

### BASIN MIXER 160MM SHEPHERDS CROOK

PRODUCT CODE: NS748-62  
 FINISH: CHROME / WHITE  
 WELS: 4 STAR - 7.5 LT/MIN

#### INFORMATION:

TEMPERATURE RATING: MIN 1° - MAX 75°  
 PRESSURE RATING: MIN 150 kPa - MAX 500 kPa



AVAILABLE IN:



FOR MORE INFORMATION VISIT  
[www.phoenixtapware.com.au](http://www.phoenixtapware.com.au)

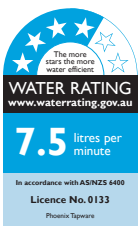
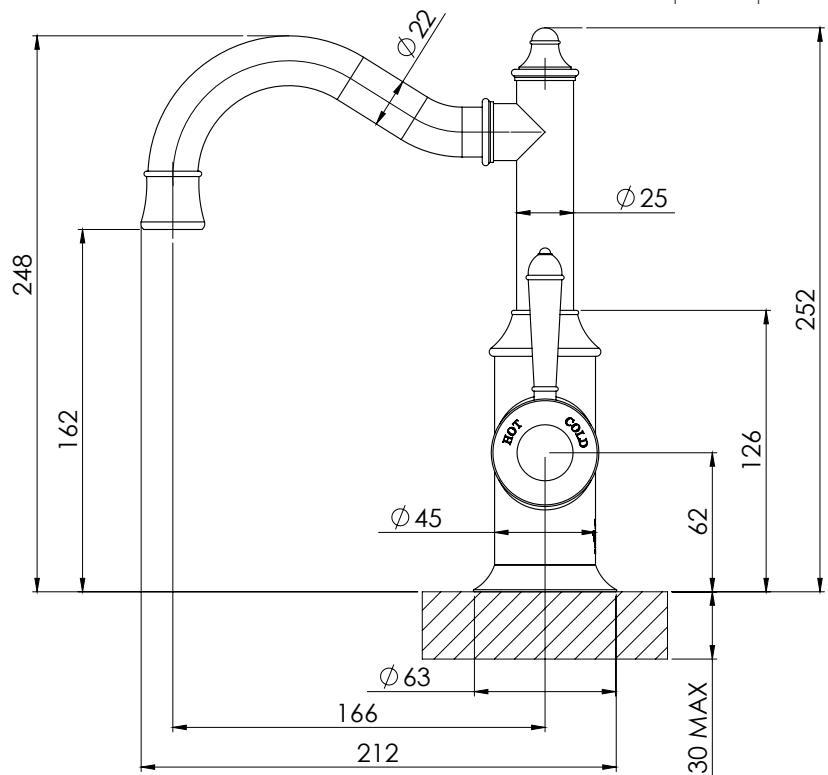
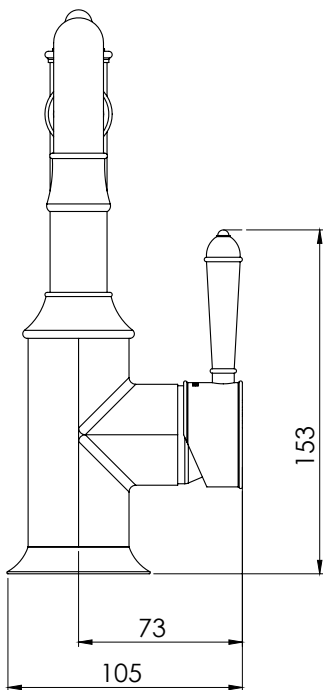

PLEASE [CLICK HERE TO VIEW FULL WARRANTY](#)

While we aim to ensure the specifications shown are correct at time of printing, Phoenix Tapware reserves the right to make modifications without prior notice. Always use the physical product measurements for mark-ups and roughing-in as the line drawing shown may differ from the actual product over time. All measurements are shown in millimetres.

Nostalgia is a Registered Trademark of Phoenix Industries Pty. Ltd.

V020518

[www.phoenixtapware.com.au](http://www.phoenixtapware.com.au)  
 03 9780 4200



# PHOENIX

## SPECIFICATIONS

### NOSTALGIA

## BASIN MIXER 160MM SHEPHERDS CROOK

PRODUCT CODE:

NS748-62

FINISH:

CHROME / WHITE

WELS:

4 STAR - 7.5 LT/MIN



### PARTS LIST

1. MIXER BODY
2. SPOUT BOSS
3. BODY COVER
4. LOWER SPOUT DISC
5. UPPER SPOUT DISC
6. SPOUT
7. O-RING 26X3.0MM
8. O-RING 7X2.5MM
9. 35MM CARTRIDGE
10. LOCKNUT
11. DOME
12. HANDLE BODY
13. LEVER PIN
14. GRUB SCREW M5X6
15. AERATOR
16. GASKET
17. RETAINER
18. M8 THREADED ROD
19. FIXING PLATE
20. FIXING RUBBER GASKET
21. M8 THREADED NUT
22. FLEXIBLE HOSE 450MM COLD
23. FLEXIBLE HOSE 450MM HOT
24. DRESS RING
25. O-RING 49X3.0MM

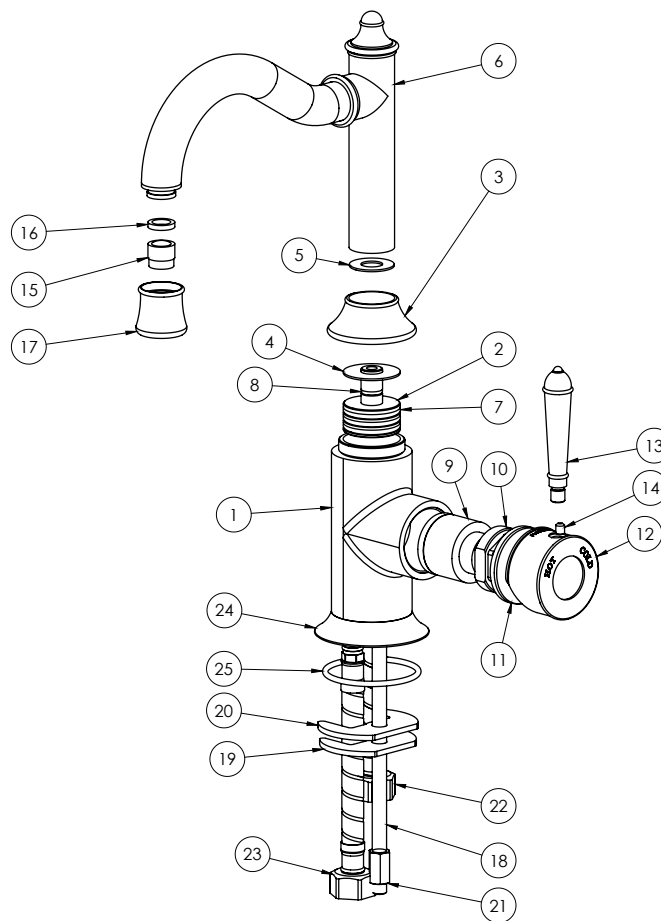

### MAINTENANCE AND CARE:

- All surfaces should be cleaned with mild liquid detergent or soap and water.
- Do not use cream cleaners or citrus based cleaning products, as they are abrasive.
- Use of unsuitable cleaning agents may damage the surface. Any damage caused in this way will not be covered by warranty.

### PACKAGING INCLUDES

- 1 x Mixer 160mm shepherds crook
- 1 x 450mm braided flexible cold hose
- 1 x 450mm braided flexible hot hose
- 1 x Installation kit
- 1 x Dress ring
- 1 x Installation instructions
- 1 x Warranty card

PLEASE [CLICK HERE](#) TO VIEW FULL WARRANTY

While we aim to ensure the specifications shown are correct at time of printing, Phoenix Tapware reserves the right to make modifications without prior notice. Always use the physical product measurements for mark-ups and roughing-in as the line drawing shown may differ from the actual product over time. All measurements are shown in millimetres.

Nostalgia is a Registered Trademark of Phoenix Industries Pty. Ltd.

V050518

[www.phoenixtapware.com.au](http://www.phoenixtapware.com.au)  
03 9780 4200