

ASSEMBLE

aw™

A81.48

Installation Instructions

- Tapware to be installed by a licenced plumber in accordance with AS/NZS 3500:2003
- Recommended working water pressure 150 - 500kPa
- Maximum water temperature is 65 deg C
- After completing the installation check function of tapware and ensure no water leaks.

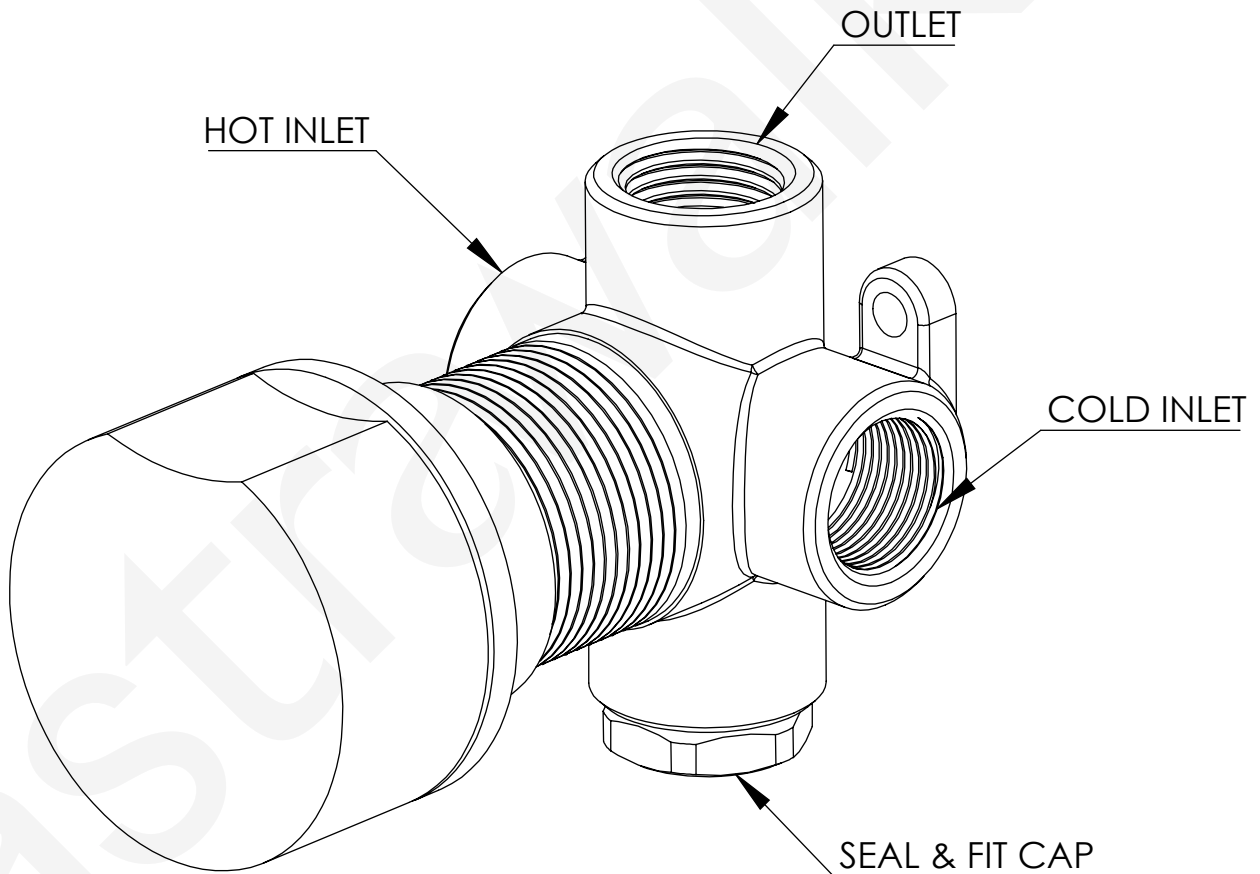

ASSEMBLE



A81.48

Installation Instructions

Install the mixer supplied to a secure nogging at the correct depth as shown in the drawing below. Ensure the mixer is square and parallel between the wall studs.

To allow the tapware to fit correctly the thickness of the finished wall surface must be calculated prior to 'rough-in'.

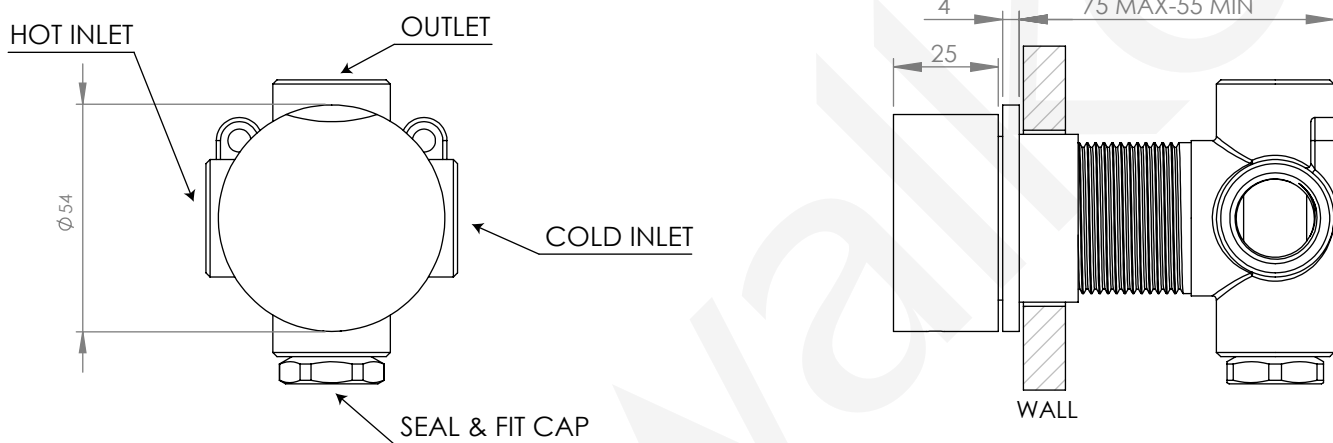

Ensure water lines are completely flushed prior to connecting the mixer.

Prior to fit off ensure the correct size cut-out around the mixer has been achieved.

Secure the cover flange for the mixer to the inwall body and ensure this is sealed and water-tight. If required, cut spindle spline to suit installation using the handle as a guide for correct tolerance. Attach handle to the spindle spline and adjust into correct position. Tighten well using an Allen Key.

