



# PHOENIX

## SPECIFICATIONS

### VIVID SLIMLINE

### VESSEL MIXER CURVED OUTLET

PRODUCT CODE: VS7901-00  
 FINISH: CHROME  
 WELS: 5 STAR - 5 LT/MIN

#### INFORMATION:

TEMPERATURE RATING: MIN 1° - MAX 75°  
 PRESSURE RATING: MIN 150 kPa - MAX 500 kPa



AVAILABLE IN:

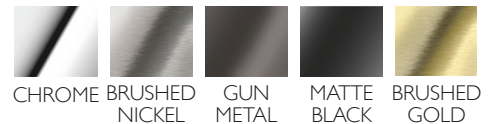

FOR MORE INFORMATION VISIT  
[www.phoenixtapware.com.au](http://www.phoenixtapware.com.au)

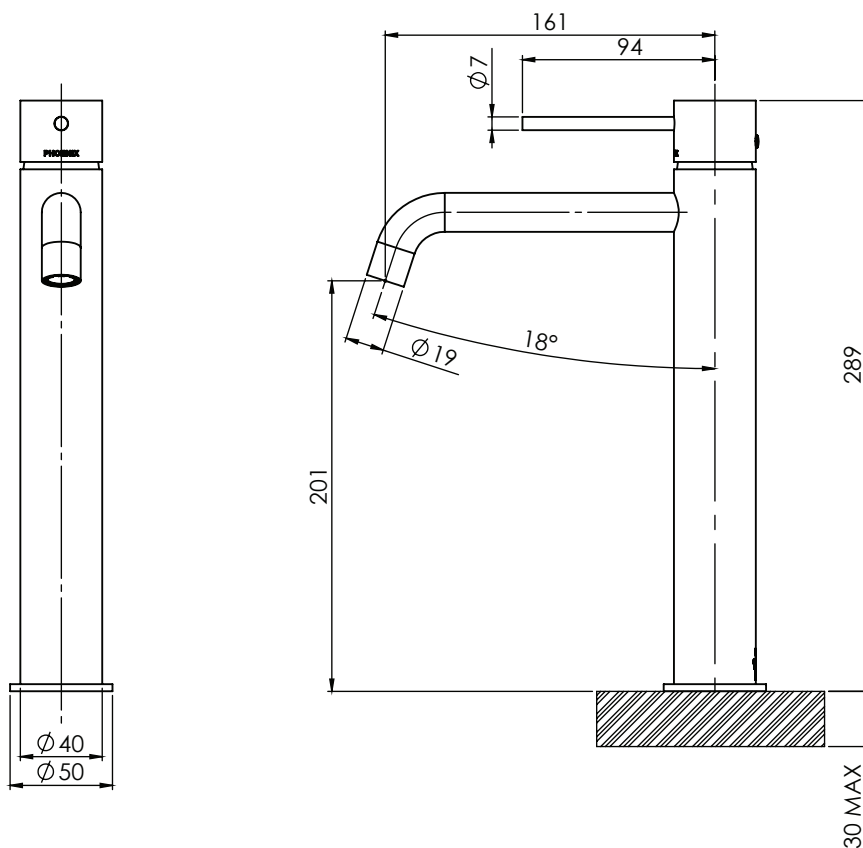

PLEASE [CLICK HERE TO VIEW FULL WARRANTY](#)

While we aim to ensure the specifications shown are correct at time of printing, Phoenix Tapware reserves the right to make modifications without prior notice. Always use the physical product measurements for mark-ups and roughing-in as the line drawing shown may differ from the actual product over time. All measurements are shown in millimetres. Some colours may vary across product types due to differing construction materials. Printed images are a representation only and the colour or finish may vary from the actual product.

[www.phoenixtapware.com.au](http://www.phoenixtapware.com.au)  
 03 9780 4200



# PHOENIX

## SPECIFICATIONS

### VIVID SLIMLINE

### VESSEL MIXER CURVED OUTLET

PRODUCT CODE: VS7901-00  
 FINISH: CHROME  
 WELS: 5 STAR - 5 LT/MIN



#### PARTS LIST

1. MIXER BODY
2. 25MM CARTRIDGE
3. MIXER LOCKNUT
4. O-RING 26X2.5MM
5. MIXER DOME
6. MIXER HANDLE
7. PIN LEVER
8. GRUB SCREW M5X5MM
9. SCREW CAP
10. AERATOR
11. DRESS PLATE
12. O-RING 39X3.5MM
13. M10 HOSE EXTENSION
14. FLEXIBLE HOSE 450MM COLD
15. FLEXIBLE HOSE 450MM HOT
16. AERATOR KEY
17. MIXER TAIL
18. LOCKNUT GASKET
19. PLASTIC MIXER LOCKNUT

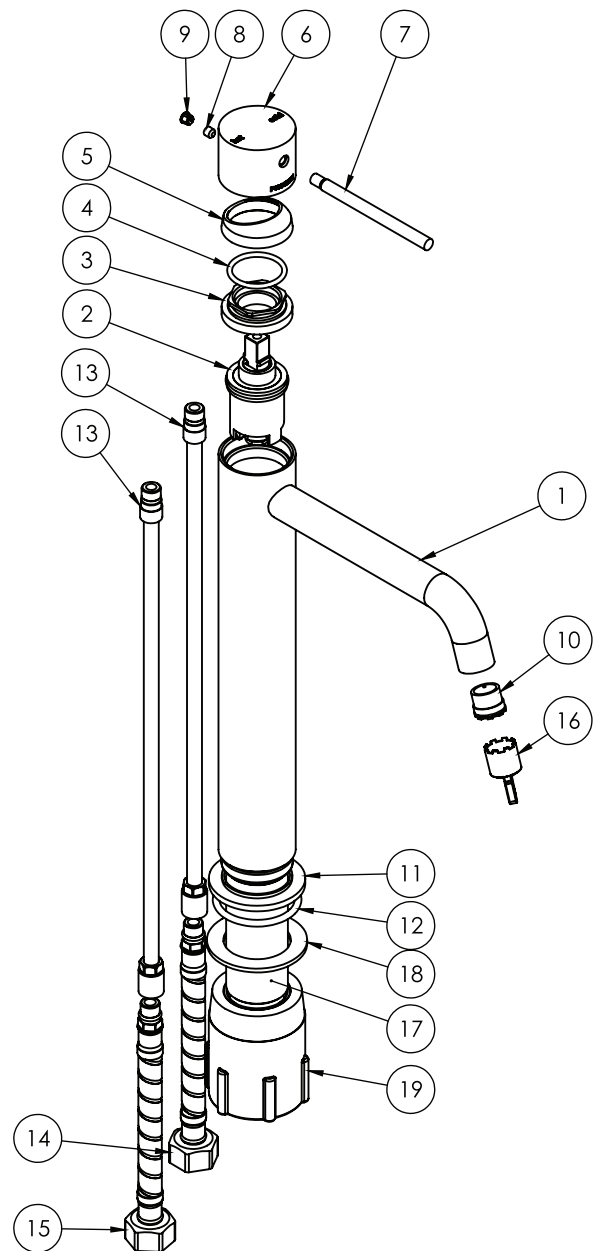

#### MAINTENANCE AND CARE:

- All surfaces should be cleaned with mild liquid detergent or soap and water.
- Do not use cream cleaners or citrus based cleaning products, as they are abrasive.
- Use of unsuitable cleaning agents may damage the surface. Any damage caused in this way will not be covered by warranty.

PLEASE [CLICK HERE TO VIEW FULL WARRANTY](#)

While we aim to ensure the specifications shown are correct at time of printing, Phoenix Tapware reserves the right to make modifications without prior notice. Always use the physical product measurements for mark-ups and roughing-in as the line drawing shown may differ from the actual product over time. All measurements are shown in millimetres. Some colours may vary across product types due to differing construction materials. Printed images are a representation only and the colour or finish may vary from the actual product.

[www.phoenixtapware.com.au](http://www.phoenixtapware.com.au)  
 03 9780 4200