

LE MUSE WALL HUNG TOILET



Features

- Modern styling exclusively for LE MUSE design suite
- Dual flush system
- WATER SAVING

Specifications

Flush system:	Wash Down
Water Use:	4.5L / 3L
Rough-in:	H=220 mm (P-Trap)
Bowl Shape:	Elongated
Water Pressure:	0.05MPa~0.75MPa
Size:	380W x 595D x 346H mm

Parts description

Fittings and Seat & Cover are not included

- **CW812JT1WS**
Elongated Wall Hung Toilet (P-Trap)
(Rough-in 220)

Optional Parts

- TC811SJ
Soft close Seat & Cover (Urea Resin)
- WH035DT1
Concealed Cistern w/Frame
- MB005DG
Flush Panel

Colors

White

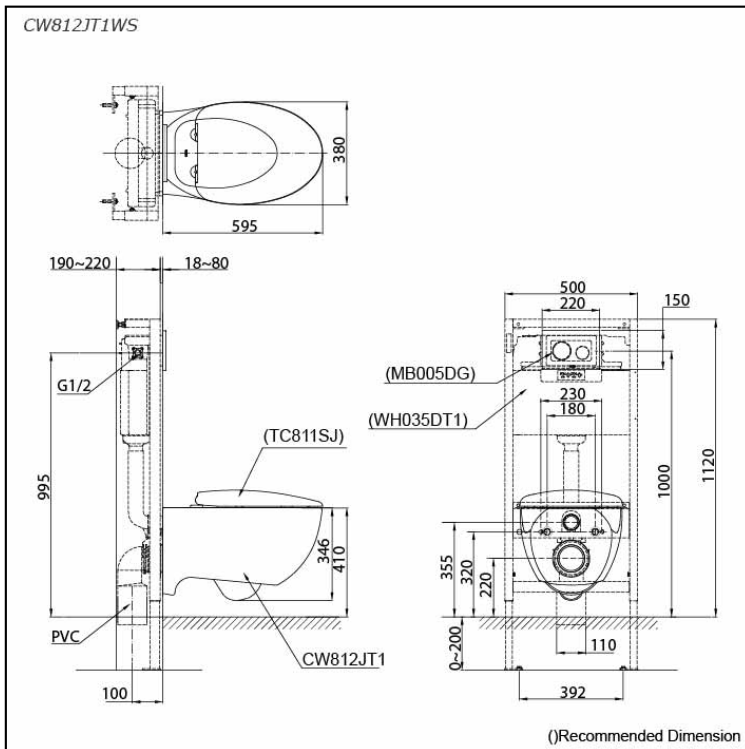

WASHLET

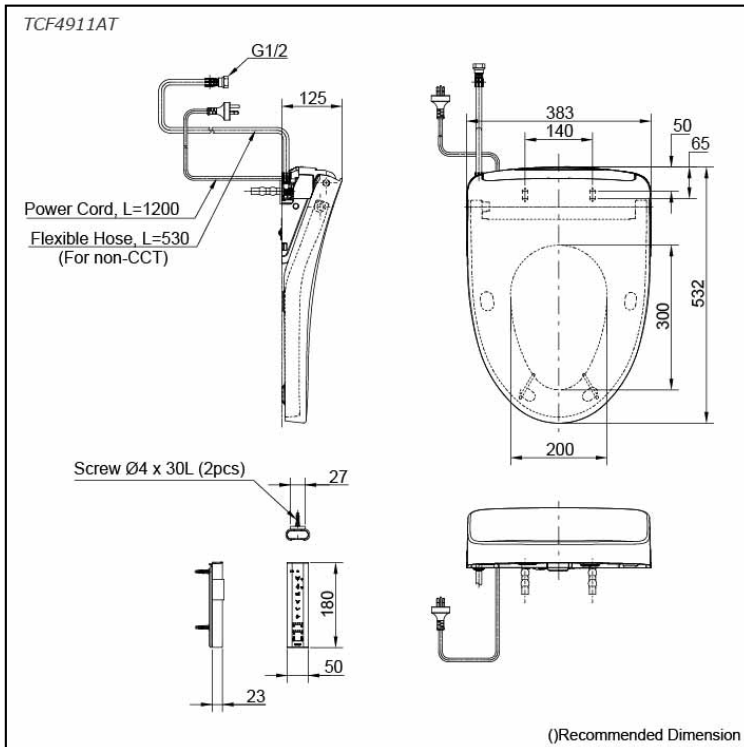

Features

- EWATER+ spreads out and keeps clean toilet bowl and nozzle by preventing bacterial with sanitizing effect
- Auto lid opening and closing
- Maximized comfort function with new wide front and pulsating cleansing
- Fully equipped with comfortable rear, front and oscillating cleansing functions
- Build-in with Motion Sensor - Microwave technology
- Infrared Sensor for remote control capabilities
- Adjustable WARM AIR DRYING
- HEATED SEAT with temperature control
- Auto powerful DEODORIZER activates after every usage

EWATER+ is made from tap water by electrolyzed chloride ion without any chemicals. After use, it returns to normal water in the state of safe and environmental friendly

Specifications

Bowl Shape:	Elongated
Water Pressure:	0.05Mpa~0.75Mpa
Power Rating:	220~240V , 50/60Hz, 830~839W
Length of Power Cord:	1.2 m
Material:	Plastic
Size:	383W x 532D x 125H mm

Parts description

- TCF4911AT WASHLET Elongated

Colors

White #NW1